

Cooling capacity = 450 Watt  
 Air-Oil Lubrication  
 Mobil DTE Light ISO VG 32

215.5

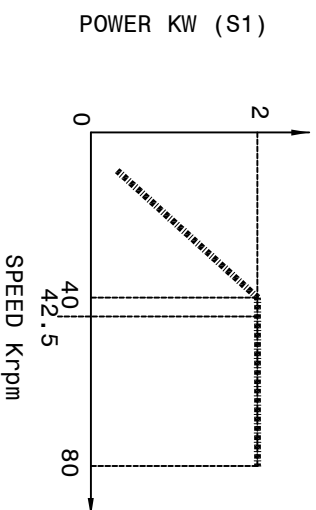
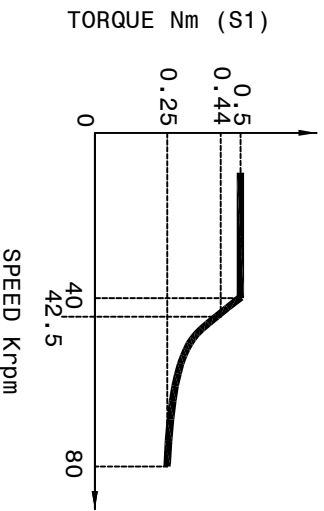
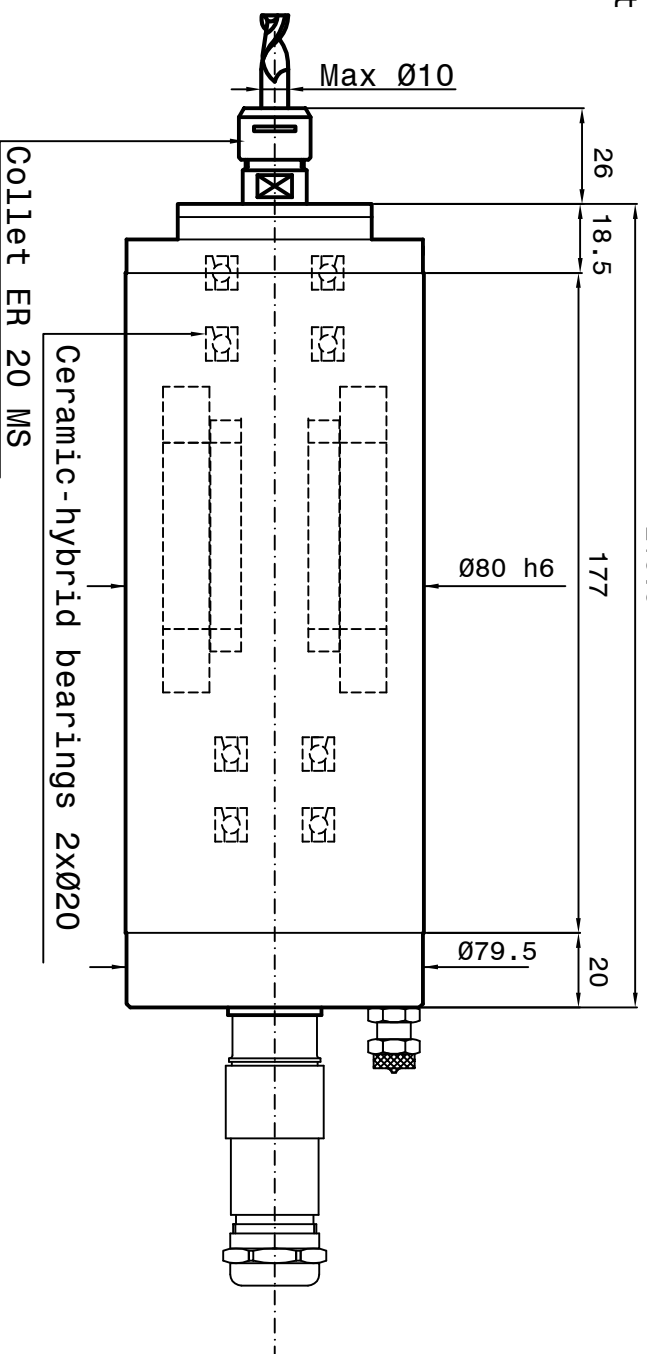
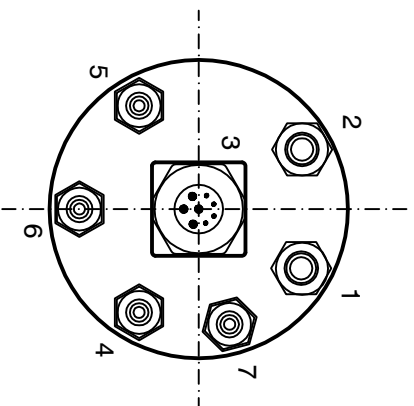

SPEED	RPM	40000	42500	80000
FREQUENCY	Hz	667	724	1333
POWER (S1)	KW	2	2	2
TORQUE (S1)	Nm	0.5	0.44	0.25
TENSION	V	350	380	380
CURRENT	A	4.5	4.2	4

- 1-Coolant inlet (G1/8") (3+4 bar) (2\*3 L/min.)
- 2-Coolant outlet (G1/8")
- 3-Electric connection  
 3Phases motor - Earth  
 Motor thermich switch (N°1 PTC 130)
- 4-Front bearings Lubrication (G1/8")
- 5-Rear bearings Lubrication (G1/8")
- 6-Unloading Lubrication bearings (G1/8")  
 through aspiration type Festo
- VAD 1/8 (6 bar)
- 7-Front-side pressurization filtered (5µm)  
 (1-1.5 bar) (G1/8")

3

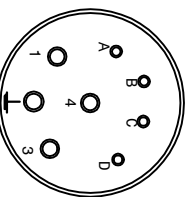

- 1 brown phase U
- 2 yellow-green Earth
- 3 blue phase V
- 4 black phase W
- A thermic switch PTC 130
- B thermic switch PTC 130
- C not connected
- D not connected

Asincronous motor: 2 poles

Runout taper 0.002mm

**Peron Speed**  
 INTERNATIONAL

SUBJECT: PSI RGC-104

CUSTOMER :

Sheet: 1/1

Dis.n° 2627-00-01

DATE : 22/08/2022