

- 1-Coolant inlet (G1/8") (3-4 bar)
- 2-Coolant outlet (G1/8")
- 3-Front-side pressurization filtered (5µm) (1-1.5 bar) (M6)
- 4-Electric connection (L=300)
- 3 Phases motor - Earth
- Motor thermal switch (N°1 NC)

SPEED	RPM	6000	40000
FREQUENCY	Hz	100	667
POWER (S1)	KW	0.6	1.6
TORQUE	Nm	0.95	0.4
TENSION	V	100	220
CURRENT	A	6.5	2

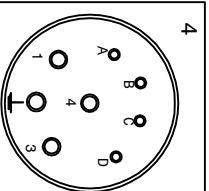
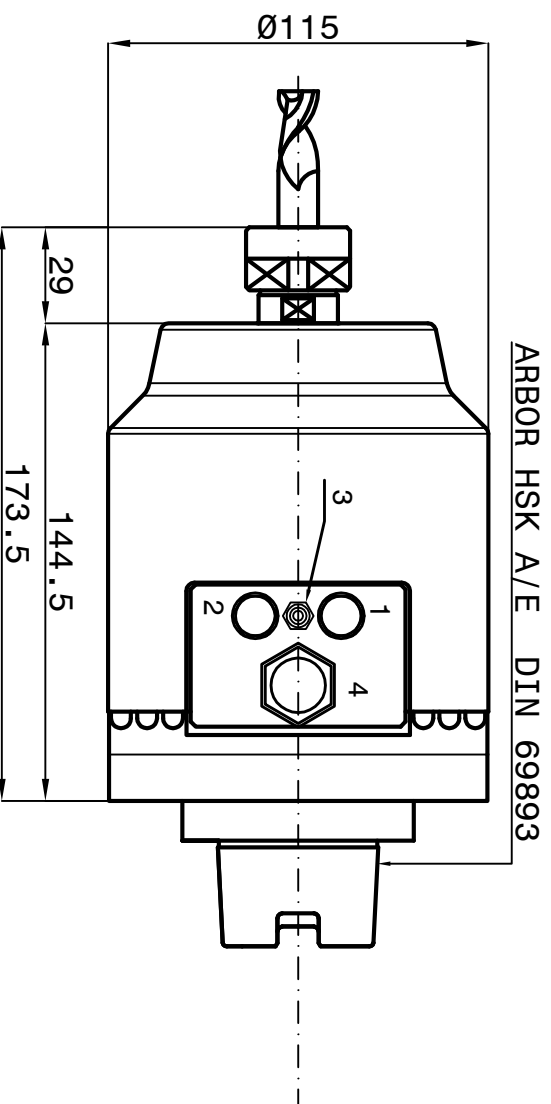
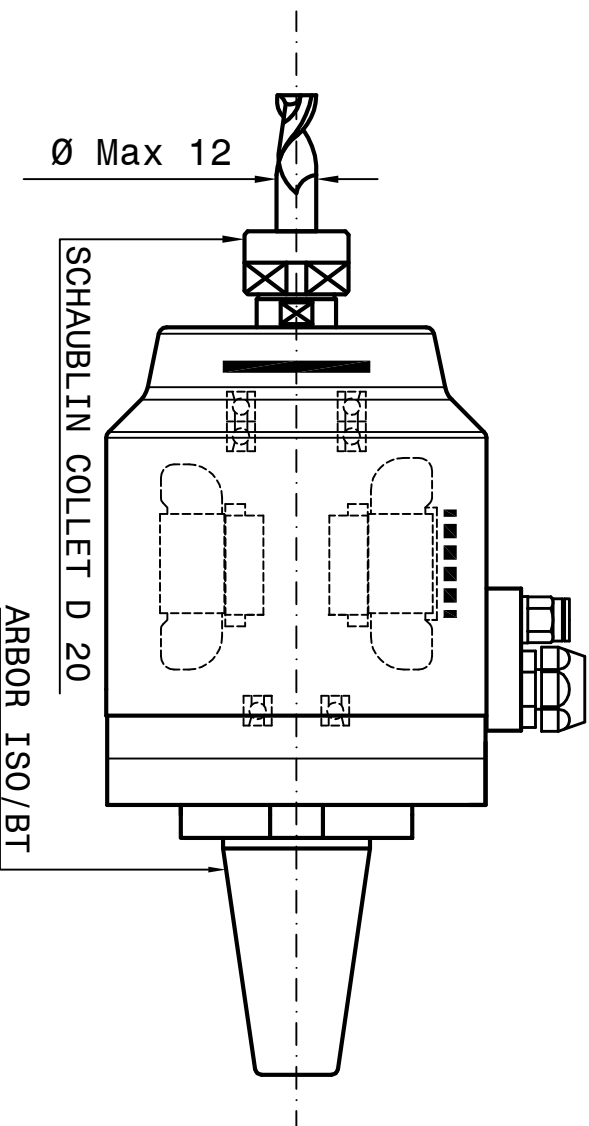

- 1 brown phase U
- 2 yellow-green Earth
- 3 blue phase V
- 4 black phase W
- A thermic switch NC
- B thermic switch NC
- C not connected
- D not connected

Peron Speed
INTERMACH

SUBJECT : PSI A-2
CUSTOMER :

Runout arbor 0.002mm

Sheet:1/1

Dwg.N°1048-00

DATE : 22/08/2022