

Cooling capacity = 950 Watt
 Air-Oil Lubrication
 Mobil DTE Light ISO VG 32

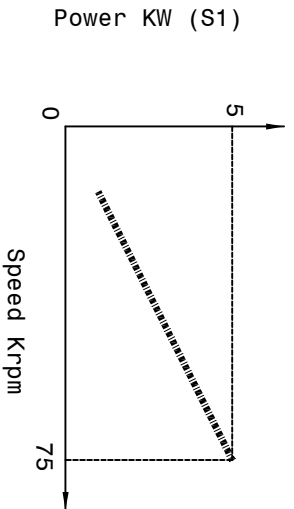
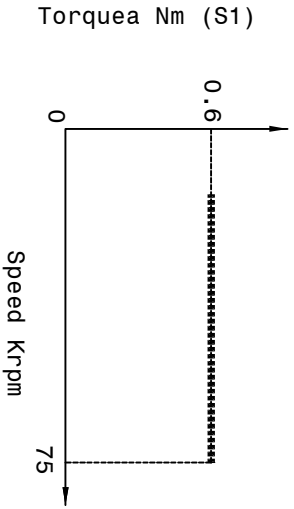
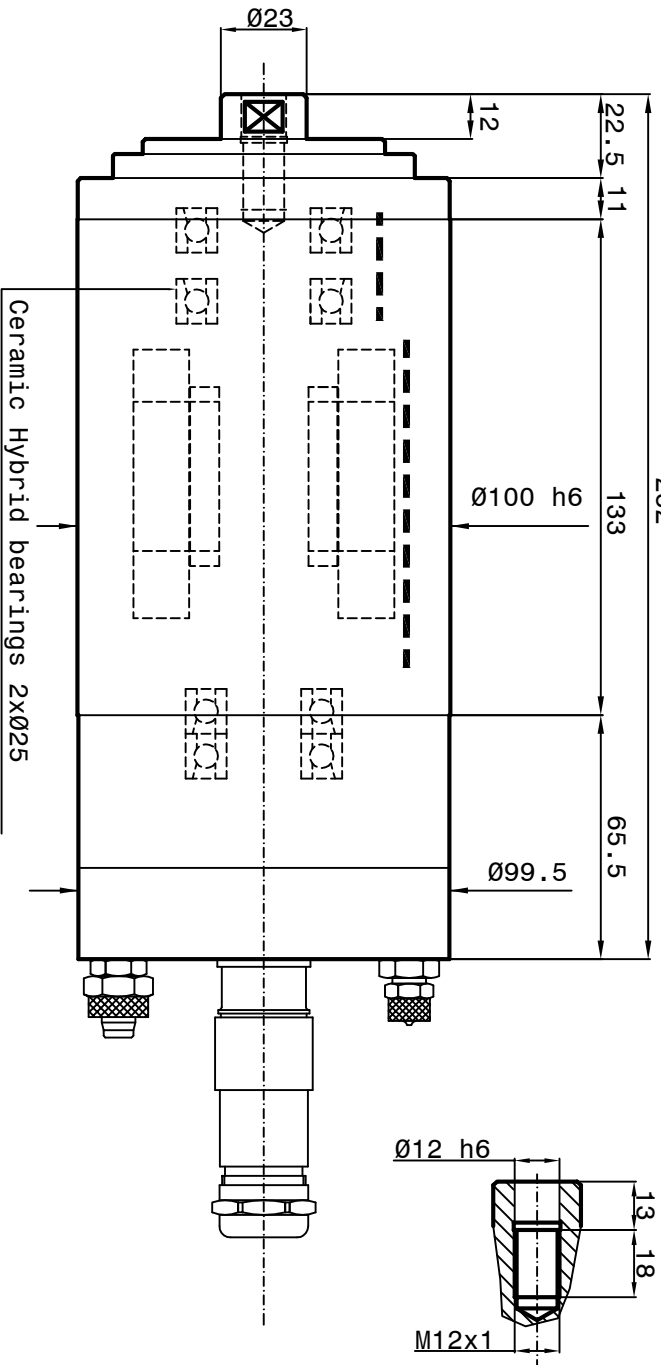
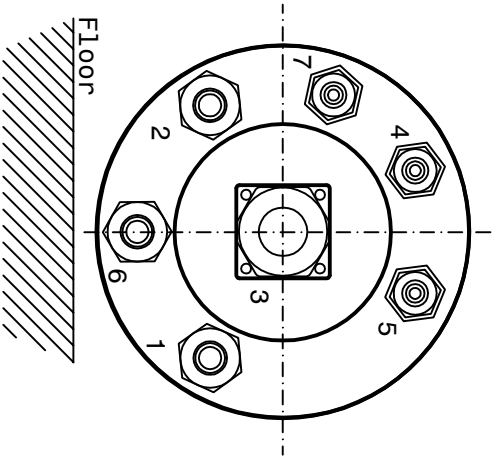

SPEED	RPM	75000
FREQUENCY	Hz	1250
POWER (S1)	KW	5
TORQUE (S1)	Nm	0.6
TENSION	V	380
CURRENT	A	10.6

Asincronous motor:2 poles

Runout taper 0.002mm

- 1-Coolant inlet (G1/8") (3+4 bar) (3+4 L/min.)
- 2-Coolant outlet (G1/8")
- 3-Electric connection
- 3Phases motor - Earth
- Motor thermich switch (N°1 PTC 130)
- 4-Front bearings Lubrication (G1/8")
- 5-Rear bearings Lubrication (G1/8")
- 6-Unloading Lubrication bearings (G1/8") through aspiration type Festo
- VAD 1/8 (6 bar)
- 7-Front-side pressurization filtered (5µm) (1-1.5 bar) (G1/8")

3

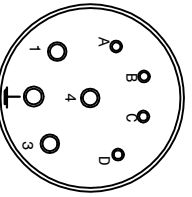

- 1 brown phase U
- 2 yellow-green Earth
- 3 blue phase V
- 4 black phase W
- A thermic switch PTC 130
- B thermic switch PTC 130
- C not connected
- D not connected

Peron Speed
 INTERNATIONAL

SUBJECT: PSI RGC-110
 CUSTOMER :

Sheet:1/1

Dis.n°5384-00

DATE : 23/08/2022